

# 7242

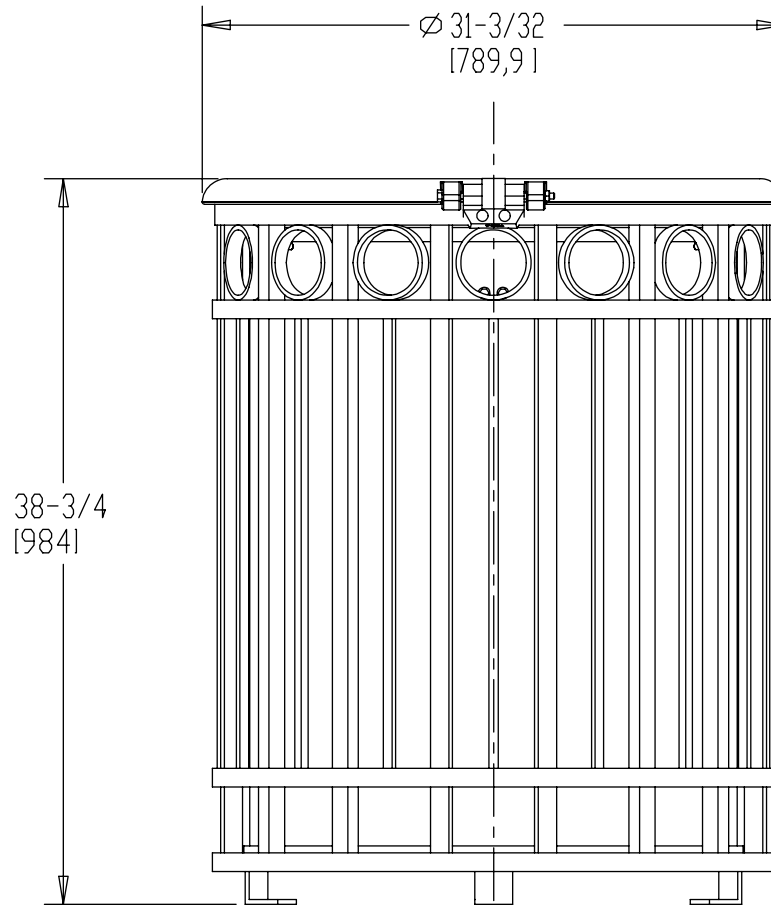
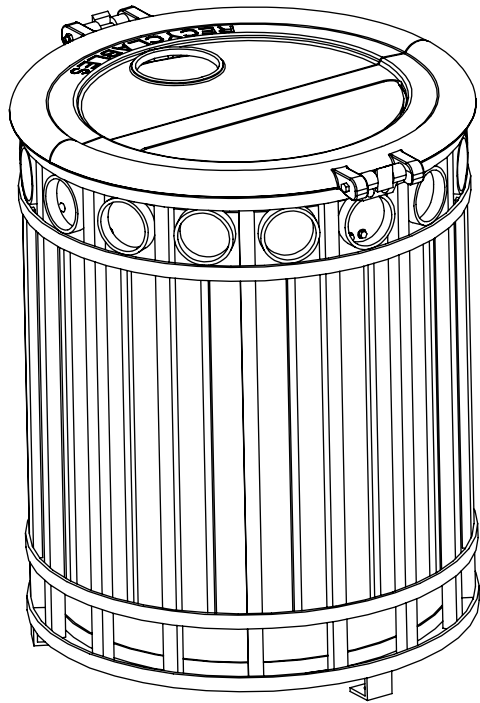

Bottom View

- Approved
- Approved as noted
- By: \_\_\_\_\_
- Revise and re-submit
- Rejected

Not to scale

## SPECIFICATIONS Recycling Container #7242

**Container** Frame is made from heavy 31mm (1") steel tube and 12mm (1/2") steel square bar with four 31mm (1") x 6mm (1/4") external steel rings all jig welded together.

**Decorative Cast Lid** Made of cast aluminum. Lid has two halves. Both halves are hinged for easy liner removal.

**Internal Liners** This container comes with two half round liners (one liner for side). Liners are 21 US gallons made of seamless polyethylene plastic.

**External Liner** Made of galvanized, 20 gauge steel and attached permanently to the container with screws.

**Mounting** Container comes standard with three feet which feature 10mm (3/8") holes for surface mounting (SM). Mounting hardware by others

**Hardware** Tamper resistant, stainless steel.

**Finish** All steel parts are zinc-plated (yellow zinc); cast aluminum parts receive a four-part corrosion inhibiting treatment prior to powder coating.

**Paint** Electrostatically applied thermoset, polyester powdercoat

**Color** Choice of five RAL colors: Graphite Black 9011, Grey Brown 8019, Moss Green 6005, Basalt Grey 7012 and Traffic White 9016. Other colors extra.

Date: \_\_\_\_\_

Project: \_\_\_\_\_

Sales Agent: \_\_\_\_\_

Model Number: 7232-POY-CRY-SM-COLOR



**HCI**  
Heritage Casting & Ironworks

1280 Fewster Drive Mississauga ON L4W 1A4  
sales@hcilighting.com [www.hcilighting.com](http://www.hcilighting.com)  
Tel. (905) 238-2648 Fax (905) 238-9060  
Toll-free (800) 267-3175