

## F340 LED Series Pendant



### Description

Luminaire is designed to fit post top mounting or pendant mounting with our ornamental arms and poles, and is suitable for wet locations. Integrated button photocell optional, and Suitable for wet locations. Finish is electrostatically applied with thermoset polyester powder-coat.



### Specification

#### Housing

Made from heavy duty cast aluminum to withstand harsh weather.

#### Hardware

All exposed hardware is made of durable stainless steel, with industrial strength seals.

#### Interior Design & Optical

Energy efficient LED driver is mounted on a removable plate, with quick disconnect wiring to allow easy driver maintenance.

L70 at 50,000 hours with CRI 70.

#### Exterior Design & Finish

Luminaire is designed to fit post top mounting or pendant mounting with our ornamental arms and poles, and is suitable for wet locations. Finish is electrostatically applied with thermoset polyester powder-coat.

Dimensions

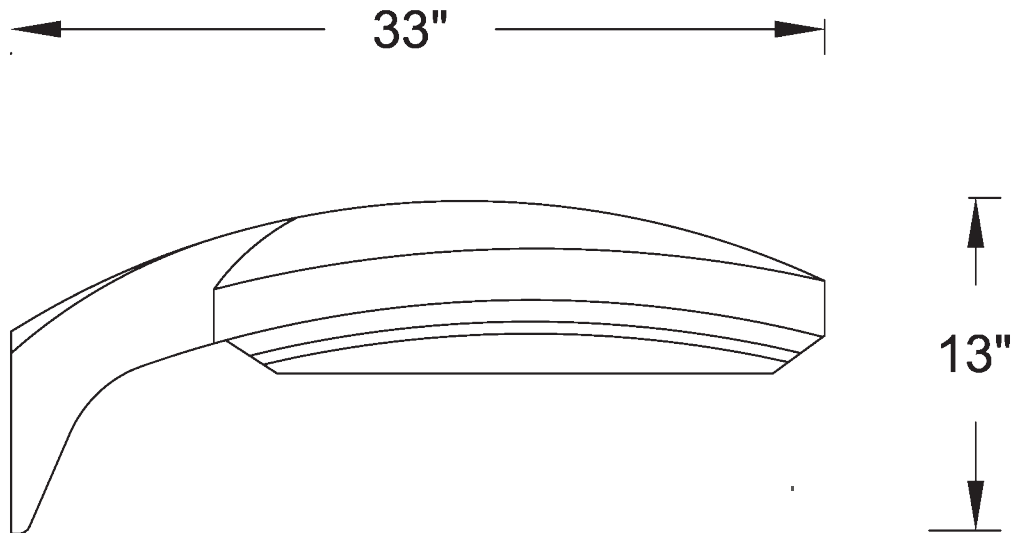

Product Ordering Number

PRODUCT	LUMENS	CCT	VOLTAGE	OPTICS	OPTIONS	FITTER	FINIALS
F340	Max 26,000 LUMENS	3000K 4000K 5000K  ±10% Variance	120v-277v  Step down transformer 347V 480V	IES TYPE II (2) III (3) IV (4) V (5)	<b>DIM</b> Dimming control <b>PCB</b> Button type photocell	N/A	N/A

**DIFFUSER TYPE**

CTG Clear tempered glass

**Color**

Standard RAL  
6005 Green  
7012 Grey  
8019 Bronze  
9011 Black/Txt  
9016 White  
Custom RAL

