

F210 LED Series



Description

The F210 Series luminaire shall consist of a clear tempered glass diffuser, a cast aluminum body and an internal optical system. The hinged diffuser shall be secured with stainless steel hardware. The ballast shall feature quick disconnect plugs for easy ballast maintenance. The ballast shall be factory wired, tested and mounted on a keyholed cast aluminum plate together with a 4kV porcelain socket. Lamps are not included and shall be supplied by others. All electrical components shall be UL listed and labeled.

Specification

Housing

Made from a spun aluminum to withstand harsh weather.

Hardware

All exposed hardware is made of durable stainless steel, with industrial strength seals.

Interior Design & Optical

Energy efficient LED driver is mounted on a removable plate, with quick disconnect wiring to allow easy driver maintenance.

L70 at 50,000 hours with CRI 70.

Exterior Design & Finish

The Luminaire is designed to fit post top mounting or pendant mounting with our ornamental arms and poles, and is suitable for wet locations.

Finish is electrostatically applied with thermoset polyester powder-coat.



Dimensions

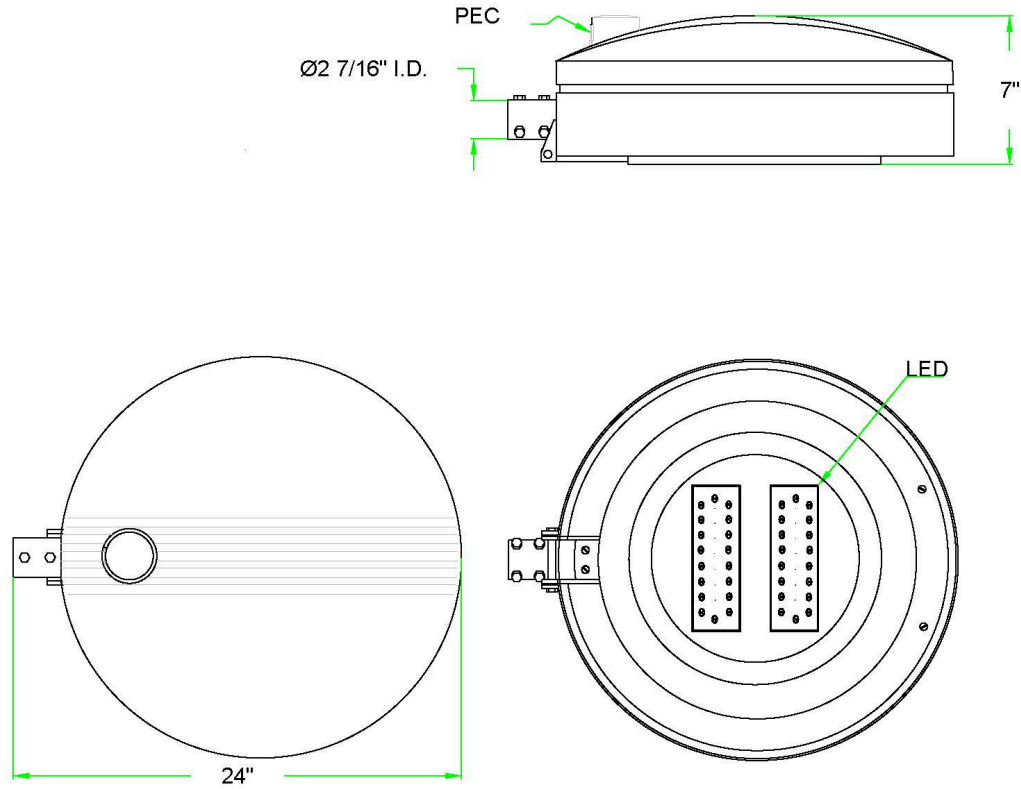

Product Ordering Number

PRODUCT	LUMENS	CCT	VOLTAGES	OPTICS	OPTIONS	FITTER	FINIAL
F210	Max 18000 LMS	3000K 4000K 5000K 6000K	120v-277v 347V 480V	IES TYPE II (2) III (3) IV (4) V (5)	DIM Dimming control PCB Button-type photo- cell HSS House side shield TWL Twist lock system	N/A	N/A

DIFFUSER TYPE

CTG- TEMPERED GLASS

Color

- Standard
- RAL
- 6005 Green
- 7012 Grey
- 8019 Bronze
- 9011
- Black/Txt
- 9016 White
- Custom RAL

