

F210 SERIES LUMINAIRE



HCI
Heritage Casting & Ironworks

1280 Fewster Drive
Mississauga ON L4W 1A4
sales@hcilighting.com
www.hcilighting.com
Fax (905) 238-9060

Toll-free (800) 267-3175 Tel. (905) 238-2648

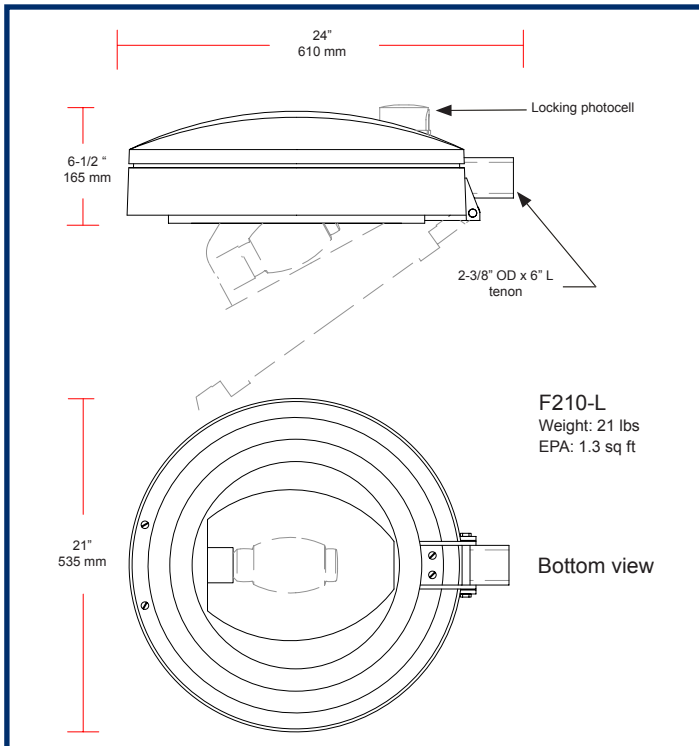

Description. The **F210** Series luminaire shall consist of a clear tempered glass diffuser, a cast aluminum body and an internal optical system. The hinged diffuser shall be secured with stainless steel hardware. The ballast shall feature quick disconnect plugs for easy ballast maintenance. The ballast shall be factory wired, tested and mounted on a keyholed cast aluminum plate together with a 4kV porcelain socket. Lamps are not included and shall be supplied by others. All electrical components shall be UL listed and labeled.

Installation. The fixture shall mount onto a 2-3/8" OD tenon and shall be secured to an arm with three hex socket screws spaced 120° apart and a security bolt.

Finish. All applicable parts shall receive a standard electrostatically applied thermoset polyester powder coat smooth semi gloss finish with a four part corrosion inhibiting process.

To assemble a catalog number, list all codes sequentially.

1. SIZE

F210-L (21"W x 6-1/2"H)

2. DIFFUSER TYPE

CTG Clear Tempered Glass

3. LIGHT SOURCE (indicate wattage)

50 - 250 MH _____W

Option: pulse start ballast

35 - 250 HPS _____W

55, 85 or 165 Philips® QL ¹ _____W

CFL Fluorescent _____W

INC Incandescent _____W

4. VOLTAGE

QT (Quad Tap 120, 208, 240, 277)

TT (Tri Tap 120, 277, 347)

NOTE: Please circle connected voltage. If none is indicated, factory will pre-wire at 120V.

120V Reactor

480 Single

5. OPTICS

SR horizontal cutoff segmented reflector IES type III or V _____

BL bare lamp

For more information on optical systems, see *Options* section. Photometrics are also available in IES format - consult factory or your HCI sales representative.

NOTES

¹ QL is available in 120V or 240V for 55W and 85W systems.

6. OPTIONS

FUS internal fusing

PEC luminaire integrated locking photocell

HSS house side shield

7. COLOR

Black RAL 9011

Green RAL 6005

Bronze RAL 8019

Grey RAL 7012

White RAL 9016

Custom