

Approval Drawing

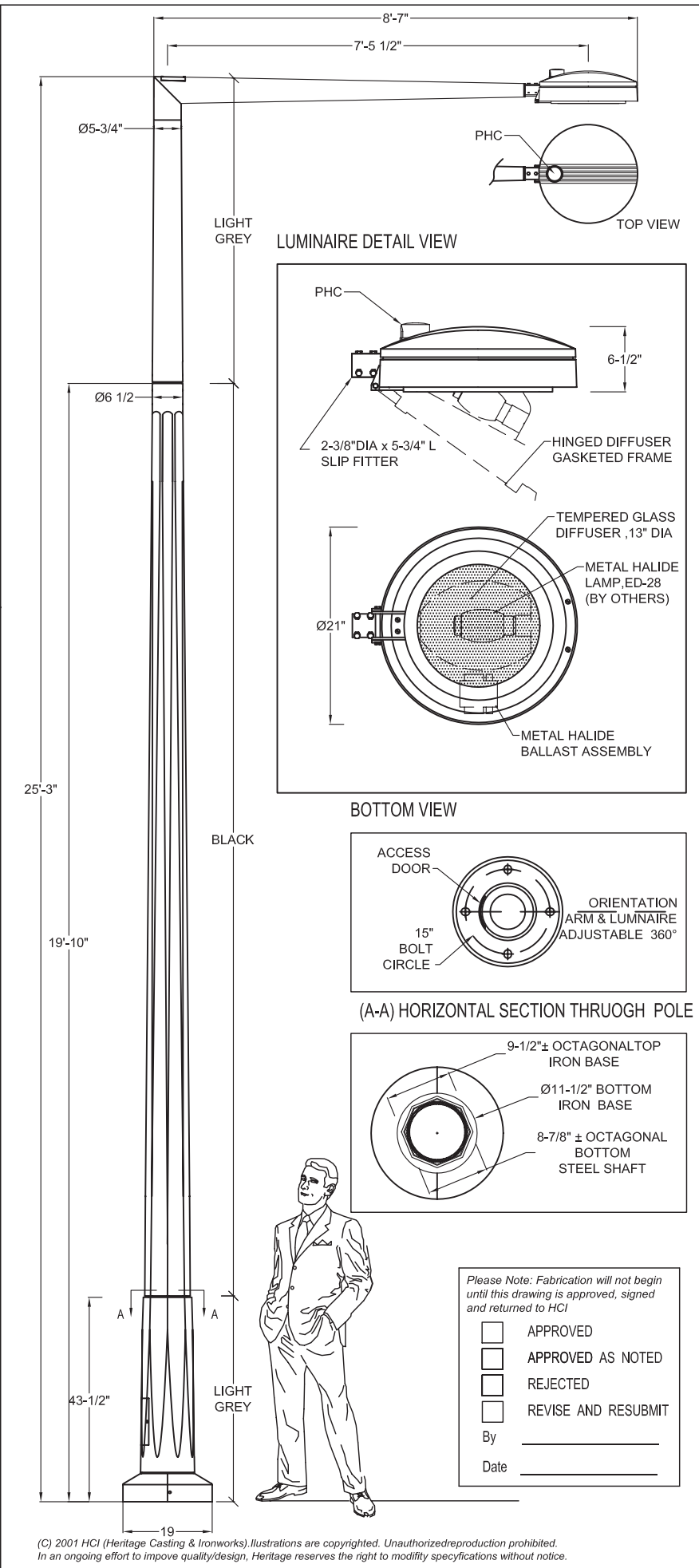

Diffuser Material: Tempered glass.
Optical System: Roadway type segmented reflector, bright anodized (Type "Alzak") IES Type III
Top Housing Material: Precision cast aluminum with integral cooling ribs and provision for mounting of photocontrol in the fixture top.
Ballast: MH high power factor mounted on removable bracket. A quick disconnect wiring system allows for fast easy ballast maintenance.
 Wattage - 250W MH (CWA)
 Voltage - 120V (QUAD)
 Socket - Mogul (4kV)
Lamp: 250W Clear MH Lamp. (By others)

Photocontrol: optional twist-lock

Pole: The base The pole shaft is a tapered steel unit, which is octagonal at the base and tapers to round shape. It is made of 11 gauge steel produced according to ASTM A513 standard. The base shall be made of heavy ductile cast iron produced according to ISO 450-10. 8"W x 10"H hand hole for electrical work as necessary. The base and steel shaft shall be assembled for accurate alignment.

Base Cover: Two piece attached to pole with two stainless steel screws.

Anchor Bolts: Four galvanized 1"(25mm) x 40" (1016mm) long . (By others)
 Template are is supplied by HCI

Finish: Electrostatically applied, thermoset polyester powder-coat finish for fixture, and sprayed-on acrylic polyurethane for pole.

Colour: Silver PCT73106 - Fixture
 Jet Black RAL 9005 - Shaft
 Light Grey RAL 7035 - Base and Arm

Date: Mar.5, 2003 Drawing No: 4336
 Model: F210-LCTG-250MH-120V-SR-3-PHC-P620-S1

Project:

Please Note: Fabrication will not begin until this drawing is approved, signed and returned to HCI



1280 Fewster Drive, Mississauga, Ontario, Canada L4W 1A4
 Tel: (905) 238-2648 Fax: (905) 238-9060
 Toll Free Canada & USA 1-800-267-3175
 E: sales@hclighting.com WEB: www.hclighting.com

(C) 2001 HCI (Heritage Casting & Ironworks). Illustrations are copyrighted. Unauthorized reproduction prohibited. In an ongoing effort to improve quality/design, Heritage reserves the right to modify specifications without notice.