

Pole (12FT, 100mph) = 10.50 sq ft  
 Luminares + Arms = 6.55 sq ft

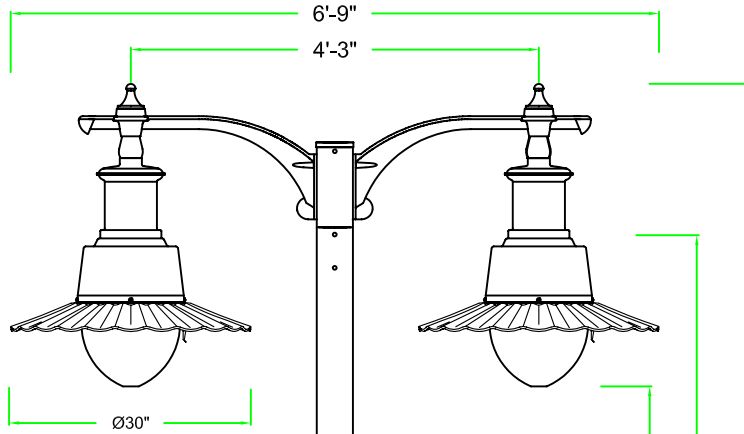

BOTTOM VIEW

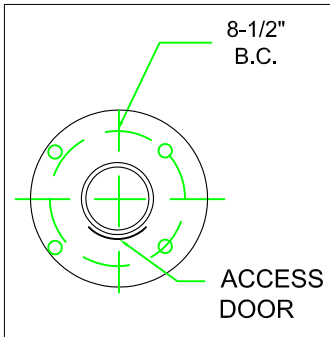

TYPE	MODEL	QTY
SA	W/ BR3	4
SB	W/ BR5	4

Please Note: Fabrication will not begin until this drawing is approved, signed and returned to HCI

- APPROVED
- APPROVED AS NOTED
- REJECTED
- REVISE AND RESUBMIT

By \_\_\_\_\_  
 Date \_\_\_\_\_



Ø4 1/2"

14'-4"

41-1/2"

Ø15"

17'-6"

16'-0"

# Approval Drawing

Light Std: F207-L-A319-2A-P430-45P-S

**Diffuser Type:** Clear.

**Diffuser Material:** Polycarbonate U.V. stabilized.

**Optical System:** Bare lamp with external prismatic refractor. IES Type III and V.

**Ballast Housing Material:** Cast aluminum.

**Decorative Shield:** Cast Aluminum.

**Ballast:** MH high power factor mounted on removable plate. A quick disconnect wiring system allows for fast easy ballast maintenance.

Wattage - 175 W

Voltage - 120V (wired) QT

Socket - Mogul (4KV).

**Photocontrol:** None

**Arm:** Cast aluminum welded to 4" -1/2 O.D. aluminum tube.

**Configuration:** 2A

**Pole:** 4"-1/2 O.D (.188TH) steel tubing welded to base plate

**Base Cover:** Two piece attached to pole with four stainless steel screws.

**Anchor Bolts:** 4 galvanized 19mm (3/4") x 609mm (24") long. Anchor bolts and metal template are supplied by HCI. Bolt circle 8-1/2"

**Finish:** Electrostatically applied, thermoset polyester powder-coat finish with XL4 four part corrosion inhibiting process.

**Colour:** Black RAL # 9011

Date: Dec.6, 2004 Drawing No: 4472-1B  
 Model: F207-L-CPC-175MH-120V-BR-3(5)  
 -A319-2A-P430-45P-S-16 -RAL9011  
 Project: ADVANTICAL FEDERAL CREDIT UNION

Please Note: Fabrication will not begin until this drawing is approved, signed and returned to HCI



1280 Fewster Drive, Mississauga, Ontario, Canada L4W 1A4  
 Tel: (905) 238-2648 Fax: (905) 238-9060  
 Toll Free Canada & USA 1-800-267-3175  
 E: sales@hclighting.com WEB: www.hclighting.com