

LUMINAIRE DETAIL

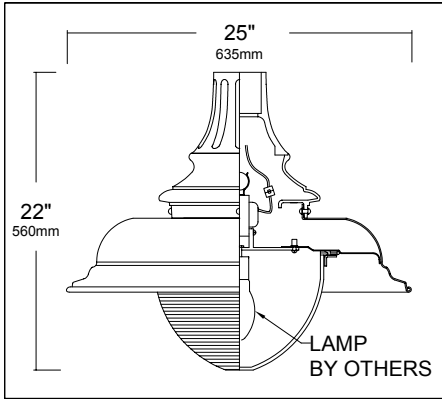

Please Note: Fabrication will not begin until this drawing is approved, signed and returned to HCI

APPROVED
 APPROVED AS NOTED
 REJECTED
 REVISE AND RESUBMIT

By _____
 Date _____

Pole (12FT, 100mph) = 5.20 sq ft
 Luminaire+Arm (38lb) = 2.72 sq ft

BOTTOM VIEW

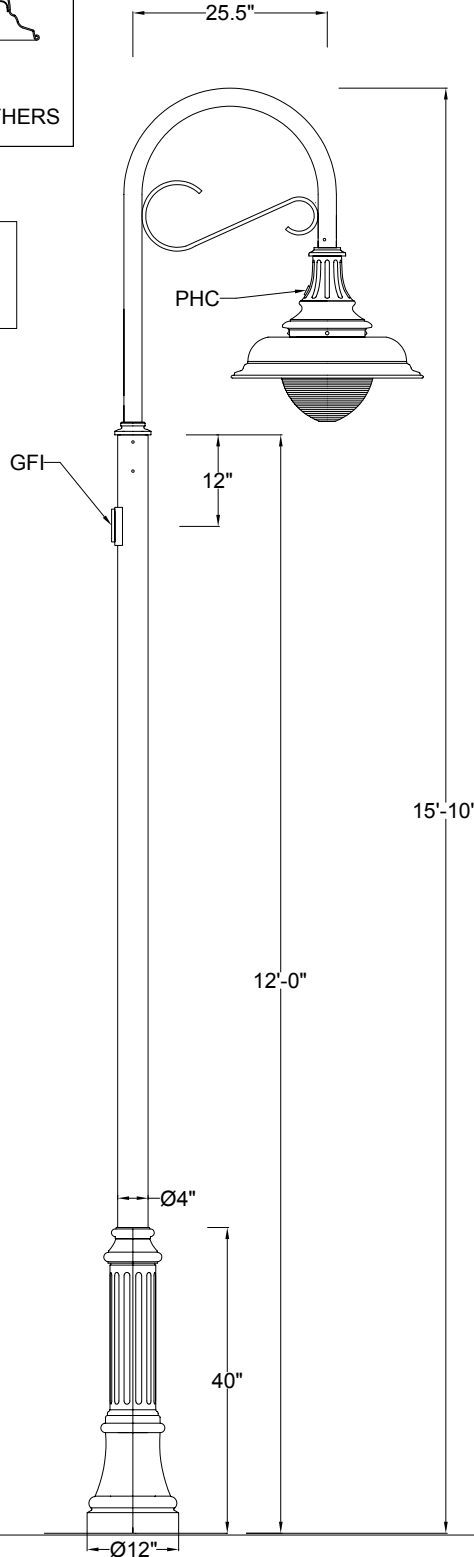
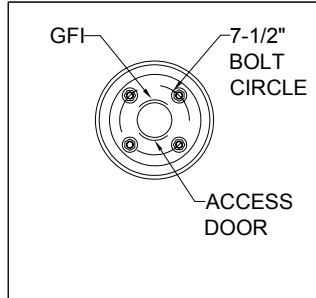

(C) 2001 HCI (Heritage Casting & Ironworks). Illustrations are copyrighted. Unauthorized reproduction prohibited. In an ongoing effort to improve quality/design, Heritage reserves the right to modify specifications without notice.

Approval Drawing

Light Standard: F199-L-P416-4P-12

Diffuser Type: Clear

Diffuser Material: Acrylic
 U.V. stabilized.

Hardware: Stainless steel

Diffuser Fitter Material: Cast Aluminum.
 and spun aluminum. Diffuser is hinged.

Ballast: HPS high power factor mounted on removable plate. A quick disconnect wiring system allows for fast easy ballast maintenance.

Wattage: 100 W

Voltage: PLEASE SPECIFY

Socket : Medium ,4kV

Photocontrol: Luminaire integrated photocell button type (120V)

Optical System: External prismatic heat resistant refractor , IES Type III

Receptacle: GFI Duplex with weatherproof cover.

Arm: 2-3/8" O.D. Aluminum tube with 1-1/2" by 1/2" TH aluminum bar scroll.

Arm Configuration: 1A

Pole Material: Fluted Aluminum
 0.250 wall thickness.

Base Cover: Two-piece cast aluminum attached to pole with four stainless steel bolts.

Anchor Bolts: Four galvanized 3/4" (19mm) x (24") long. Anchor bolts and metal template supplied by HCI.

Finish: Electrostatically applied, thermoset polyester powder-coat finish with XL4 four part corrosion inhibiting process.

Color: "Custom RAL 6005 (Dark Green) Smooth Mat 20° -25° gloss"

Date: Mar.11, 2003. Drawing No: 4334A
 Model: F199-L-CAC-F3-100HPS-VOLT-BR-3-PCB1-L-
 -A361-SCR-1A-P416-4PC-12-GFI-RAL6005

Project: SALEM HEIGHTS

Approved as illustrated: Date:

Approved with changes: Date:

Approved By:

Type: Notes:

Please Note: Fabrication will not begin until this drawing is approved, signed and returned to HCI



1280 Fewster Drive, Mississauga, Ontario, Canada L4W 1A4
 Tel: (905) 238-2648 Fax: (905) 238-9060
 Toll Free Canada & USA 1-800-267-3175
 E: sales@hclighting.com WEB: www.hclighting.com