

F197 LED Series Post Top



Description

The F197 Series luminaire shall consist of a paneled diffuser, a cast aluminum body and an internal optical system. The hinged diffuser shall be secured with stainless steel hardware. The ballast LED assembly shall feature quick disconnect plugs for easy maintenance. The LED shall be factory wired, tested and mounted on a keyholed cast aluminum plate. All electrical components shall be UL listed and labeled.

Specification

Housing

Made from heavy duty cast aluminum to withstand harsh weather.

Hardware

All exposed hardware is made of durable stainless steel, with industrial strength seals.

Interior Design & Optical

Energy efficient LED driver is mounted on a removable plate, with quick disconnect wiring to allow easy driver maintenance.

L70 at 50,000 hours with CRI 70.

Exterior Design & Finish

Luminaire is designed to fit post top mounting or pendant mounting with our ornamental arms and poles, and is suitable for wet locations. Finish is electrostatically applied with thermoset polyester powder-coat.



Dimensions

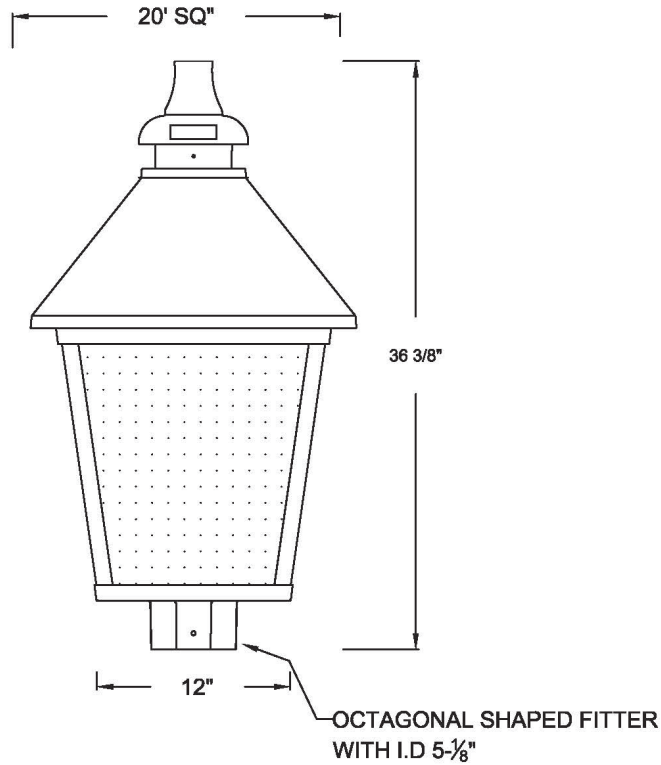

Product Ordering Number

PRODUCT	LUMENS	CCT	VOLTAGE	OPTICS	OPTIONS	FITTER	FINIALS
F197	Max 18,900 LUMENS	3000K 4000K 5000K 6000K =10% Variance	120v-277v Step down transformer 347V 480V	IES TYPE II (2) III (3) IV (4) V (5)	DIM Dimming control PCB Button type photocell HSS House side shield	N/A	N/A

DIFFUSER TYPE

- CAC** Clear acrylic
- FAC** Frosted acrylic
- WAC** White acrylic
- CPC** Clear polycarbonate
- CTG** clear tempered glass
- WPC** white polycarbonate

Color

- Standard RAL
- 6005 Green
- 7012 Grey
- 8019 Bronze
- 9011 Black/Txt
- 9016 White
- Custom RAL

