

Approval Drawing

Light Std: F178-L-A355-1A-P450-4P

Please Note: Fabrication will not begin until this drawing is approved, signed and returned to HCI

- APPROVED
- APPROVED AS NOTED
- REJECTED
- REVISE AND RESUBMIT

By _____
Date _____

Luminaire + Arm EPA : 3.80 sq ft.
Pole 14 Ft (100mph) EPA : 8.75 sq ft.

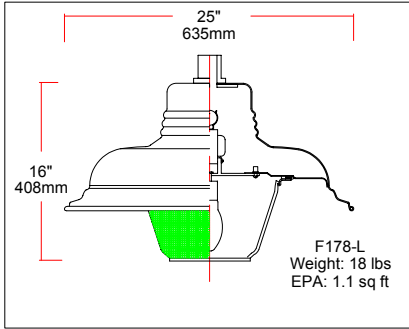

BOTTOM VIEW

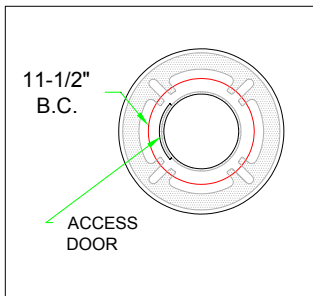

(C) 2001 HCI (Heritage Casting & Ironworks). Illustrations are copyrighted. Unauthorized reproduction prohibited. In an ongoing effort to improve quality/design, Heritage reserves the right to modify specifications without notice.

Diffuser Type: Clear.

Diffuser Material: Polycarbonate U.V. stabilized.

Optical System: Bare lamp with closed bottom external prismatic refractor.

Light Distribution: IES Type III

Diffuser Holder: The diffuser is mounted on a hinged retaining ring. The design causes uniform pressure on a silicone gasket resulting in a dust and weather proof seal.

Ballast: MH high power factor mounted in the base. A quick disconnect wiring system allows for fast easy ballast maintenance.

Wattage - 175W MH

Voltage - (QT) PLEASE SPECIFY

Socket - Medium (4KV).

Photocontrol: None

Arm: Two 2" by 3" rectangular extruded aluminum arms welded to the side of 4.5" O.D. aluminum column and closed by aluminum cap.

Pole: 4"OD x .226wall 6061 T6 aluminum extrusion tube welded over and in a 8-5/8" dia. aluminum tube.

Base Cover Material: Cast aluminum. Made in one piece integrated construction with 7" W x 8" H hand hole.

Anchor Bolts: 4 galvanized 19mm (3/4") x 610mm (24") long. A steel bolt circle template is supplied by HCI.

Finish: Electrostatically applied, thermoset polyester powder-coat finish with XL4 four part corrosion inhibiting process.

Colour: PLEASE SPECIFY.

Date: Jan.23, 2004 Drawing No: 4418

Model: F178-L-EPC-175MH-QT-BL-3-A355-1A-P450-4PC-14-Color

Project: Modesto Pedestrian Parkway

Please Note: Fabrication will not begin until this drawing is approved, signed and returned to HCI



1280 Fewster Drive, Mississauga, Ontario, Canada L4W 1A4
Tel: (905) 238-2648 Fax: (905) 238-9060
Toll Free Canada & USA 1-800-267-3175
E: sales@hcilighting.com WEB: www.hcilighting.com