

## F174 LED Series Pendant



### Description

The F174 Series luminaire shall consist of an injection-molded UV stabilized diffuser, a spun aluminum hood and shade assembly, and an internal optical system. The diffuser shall be secured with stainless steel hardware. The LED shall feature quick disconnect plugs for easy maintenance. The LED shall be factory wired, tested and mounted on a keyholed cast aluminum plate. All electrical components shall be UL listed and labeled.

### Specification

#### Housing

Made from a spun aluminum to withstand harsh weather.

#### Hardware

All exposed hardware is made of durable stainless steel, with industrial strength seals.

#### Interior Design & Optical

Energy efficient LED driver is mounted on a removable plate, with quick disconnect wiring to allow easy driver maintenance.  
L70 at 50,000 hours with  $CRI \geq 70$ .

#### Exterior Design & Finish

Luminaire is designed to fit post top mounting or pendant mounting with our ornamental arms and poles, and is suitable for wet locations.

Finish is electrostatically applied with thermoset polyester powder-coat.



### Dimensions

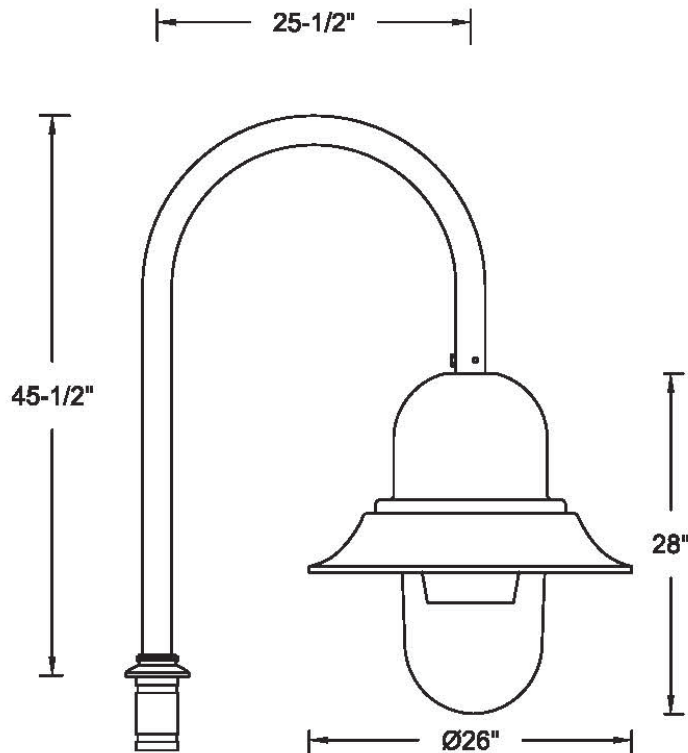

### Product Ordering Number

PRODUCT	LUMENS	CCT	VOLTAGE	OPTICS	OPTIONS	FITTER	FINIALS
F174	Max ?	3000K 4000K 5000K 6000K  =10% Vari- ance	120v-277v  Step down transformer 347V 480V	IES TYPE II (2) III (3) IV (4) V (5)	<b>DIM</b> Dimming control <b>PCB</b> Button type photo- cell <b>HSS</b> House side shield <b>TWL</b> Twist lock system	N/A	N/A

#### DIFFUSER TYPE

- CACX** Clear acrylic textured
- CPCX** Clear polycarbonate textured
- FACX** Frosted acrylic textured
- WACX** White acrylic textured

#### Color

- Standard
- RAL
- 6005 Green
- 7012 Grey
- 8019 Bronze
- 9011
- Black/Txt
- 9016 White
- Custom RAL

