

F170 LED Series



Description

The F170 Series luminaire shall consist of an injection-molded UV stabilized diffuser, a spun aluminum hood assembly, an aluminum cage and an internal optical system. The aluminum cage shall consist of four extruded aluminum struts and a cast aluminum ring welded together. The diffuser shall be secured to the gasketed fitter with stainless steel hardware. The LED shall feature quick disconnect plugs for easy maintenance. The LED shall be factory wired, tested and mounted on a keyholed cast aluminum plate. All electrical components shall be UL listed and labeled.

Specification

Housing

Made from heavy duty cast aluminum to withstand harsh weather.

Hardware

All exposed hardware is made of durable stainless steel, with industrial strength seals.

Interior Design & Optical

Energy efficient LED driver is mounted on a removable plate, with quick disconnect wiring to allow easy driver maintenance.

L70 at 50,000 hours with CRI 70.

Exterior Design & Finish

Luminaire is designed to fit post top mounting or pendant mounting with our ornamental arms and poles, and is suitable for wet locations.

Finish is electrostatically applied with thermoset polyester powder-coat.



Dimensions

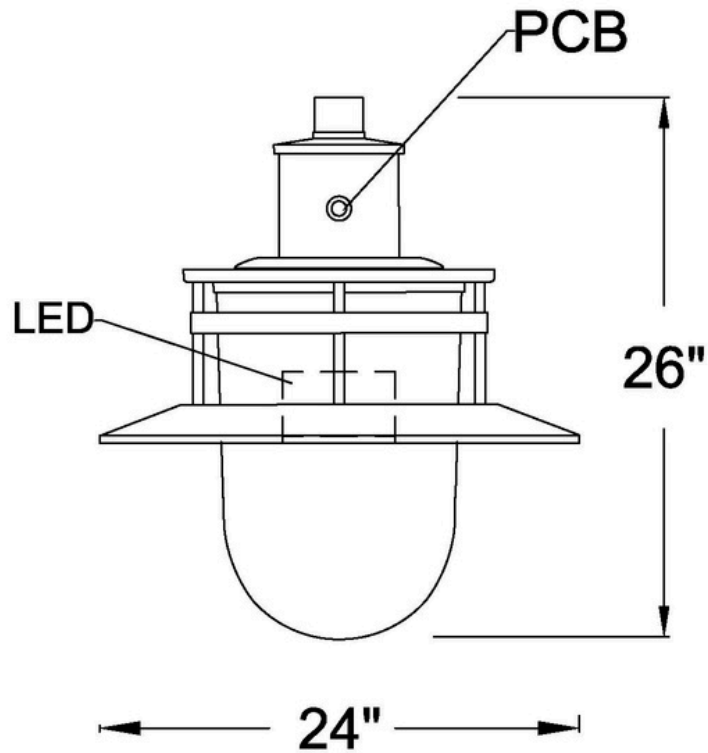

Product Ordering Number

PRODUCT	LUMENS	CCT	VOLTAGES	OPTICS	OPTIONS	FITTER	FINIAL
F170	Max 18000 LMS	3000K 4000K 5000K 6000K	120v-277v 347V 480V	IES TYPE II (2) III (3) IV (4) V (5)	DIM Dimming control PCB Button-type photo- cell HSS House side shield TWL Twist lock system	N/A	N/A

DIFFUSER TYPE

- CACX Clear acrylic textured
- CPCX Clear polycarbonate textured
- FACX Frosted acrylic textured
- WACX White acrylic textured

Color

- Standard
- RAL
- 6005 Green
- 7012 Grey
- 8019 Bronze
- 9011
- Black/Txt
- 9016 White
- Custom RAL

