

F154 SERIES LUMINAIRE



HCI
Heritage Casting & Ironworks

1280 Fewster Drive
Mississauga ON L4W 1A4
sales@hcilighting.com
www.hcilighting.com
Fax (905) 238-9060

Toll-free (800) 267-3175 Tel. (905) 238-2648

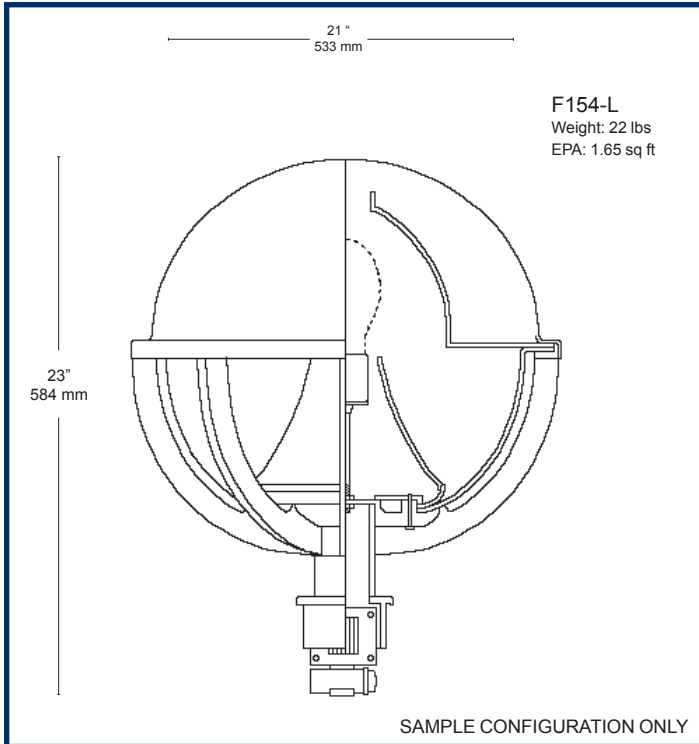

Description. The **F154** Series luminaire shall consist of a spun aluminum hood, an injection-molded UV stabilized globe, an aluminum cage, an internal optical system and a mechanically fastened slip fitter (capital). The aluminum cage shall consist of eight cast aluminum struts and a cast aluminum ring jig-welded together. The cage shall be mechanically fastened to an extruded aluminum slip fitter with three stainless steel socket set screws. The fitter shall house the ballast assembly. The ballast shall feature quick disconnect plugs for easy ballast maintenance. It shall be factory wired, tested and mounted on a keyholed cast aluminum plate together with a 4kV porcelain socket. Lamps are not included and shall be supplied by others. All electrical components shall be UL listed and labeled.

Installation. The fixture shall slip fit onto a 3-3/4" ID tenon and shall be secured to the pole with three sets of two s/s hex socket screws spaced 120° apart.

Finish. All applicable parts shall receive a standard electrostatically applied thermoset polyester powder coat smooth semi gloss finish with a four part corrosion inhibiting process.

To assemble a catalog number, list all codes sequentially.

1. SIZE

F154-L (21"W x 23"H)

2. DIFFUSER TYPE

CAC Clear Acrylic

CPC Clear Polycarbonate

WAC White Acrylic

WPC White Polycarbonate

3. LIGHT SOURCE (indicate wattage)

50 or 70 **MH** _____ W

Option: pulse start ballast

35 - 70 **HPS** _____ W

CFL Fluorescent _____ W

INC Incandescent _____ W

4. OPTICS

OC dual optical cone IES type V

BL bare lamp
(recommended for white diffusers only)

5. VOLTAGE (circle connected voltage)

QT (Quad Tap 120, 208, 240, 277)

TT (Tri Tap 120, 277, 347)

NOTE: Please circle connected voltage. If none is indicated, factory will pre-wire at 120V.

120V Reactor

480 Single

6. OPTIONS

FUS internal fusing

HSS house side shield

7. COLOR

Black RAL 9011

Green RAL 6005

Bronze RAL 8019

Grey RAL 7012

White RAL 9016

Custom