

## F119 LED Series Post Top



### Description

- Ornamental Die-Cast aluminum base
- Tool-Less latching system
- Quick disconnect driver system mounted on removable plate
- Integrated button photocell optional
- Suitable for wet locations
- IES II, III AND V
- Powder coated finish

### Specification

#### Housing

Made from heavy duty cast aluminum to withstand harsh weather.

#### Hardware

All exposed hardware is made of durable stainless steel, with industrial strength seals.

#### Interior Design & Optical

Energy efficient LED driver is mounted on a removable plate, with quick disconnect wiring to allow easy driver maintenance.

L70 at 50,000 hours with CRI 70.

#### Exterior Design & Finish

Luminaire is designed to fit post top mounting or pendant mounting with our ornamental arms and poles, and is suitable for wet locations. Finish is electrostatically applied with thermoset polyester powder-coat.



**Dimensions**

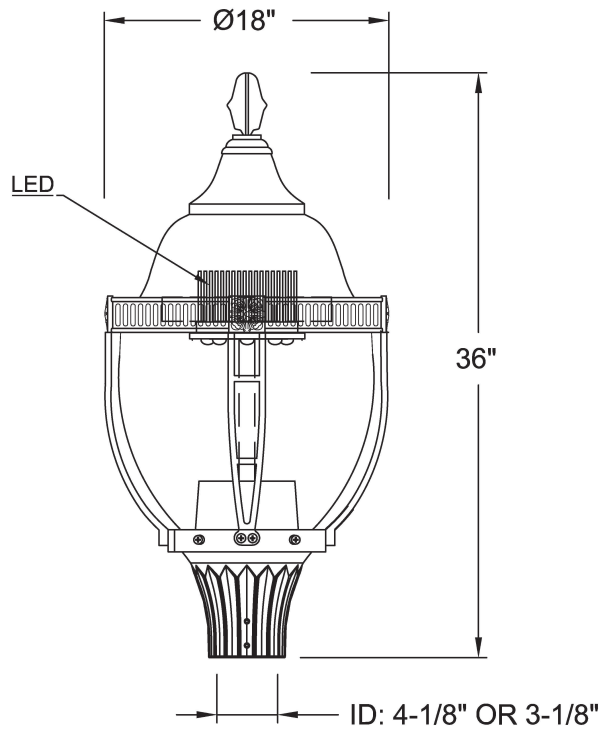

**Product Ordering Number**

PRODUCT	LUMENS	CCT	VOLTAGE	OPTICS	OPTIONS	FITTER	FINIALS
F119	Max 12,600 LUMENS	3000K 4000K 5000K 6000K  =10% Variance	120v-277v  Step down transformer 347V 480V	IES TYPE II (2) III (3) IV (4) V (5)	<b>DIM</b> Dimming control <b>PCB</b> Button type photocell <b>HSS</b> House side shield <b>TWL</b> Twist lock system	A, B C, D E, F G, H I, J K, L M, Q R, T U	FA FB FC FD FE FF FG FH FI FJ

**DIFFUSER TYPE**

**CAC** CLEAR ACRYLIC  
**FAC** FROSTED ACRYLIC

**Color**

Standard RAL  
6005 Green  
7012 Grey  
8019 Bronze  
9011 Black/Txt  
9016 White  
Custom RAL

