

F113 LED Series Post Top



Description

- The F113 Series luminaire shall consist of an injection-molded UV stabilized acorn-diffuser, an aluminum cage, an internal optical system and a mechanically fastened slip fitter (capital).
- The cage shall consist of four struts and a ring jig-welded together. The cage and the diffuser shall be secured to the cast aluminum fitter with stainless steel hardware.
- The fitter shall be made of cast aluminum and shall house an LED assembly. The LED shall feature quick disconnect plugs for easy maintenance.

Specification

Housing

Made from heavy duty cast aluminum to withstand harsh weather.

Hardware

All exposed hardware is made of durable stainless steel, with industrial strength seals.

Interior Design & Optical

Energy efficient LED driver is mounted on a removable plate, with quick disconnect wiring to allow easy driver maintenance.

L70 at 50,000 hours with CRI 70.

Exterior Design & Finish

Luminaire is designed to fit post top mounting or pendant mounting with our ornamental arms and poles, and is suitable for wet locations. Finish is electrostatically applied with thermoset polyester powder-coat.



Dimensions

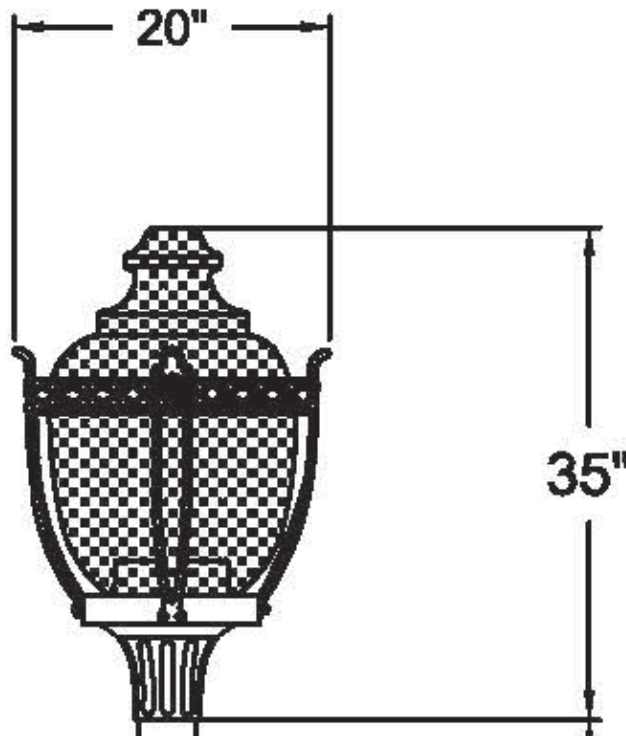

Product Ordering Number

PRODUCT	LUMENS	CCT	VOLTAGE	OPTICS	OPTIONS	FITTER	FINIALS
F113	Max LUMENS 15,700 Large 6300 small	3000K 4000K 5000K 6000K =10% Variance	120v-277v Step down transformer 347V 480V	IES TYPE II (2) III (3) IV (4) V (5)	DIM Dimming control PCB Button type photocell HSS House side shield TWL Twist lock system	A, B C, D E, F G, H I, J K, L M, Q R, T U	FA FB FC FD FE FF FG FH FI FJ

DIFFUSER TYPE

- CACX** Clear acrylic textured
- CPCX** Clear polycarbonate textured
- FACX** Frosted acrylic textured
- WACX** White acrylic textured
- Extra option for small
- WPEX** White polyethylene textured

Color

- Standard RAL
- 6005 Green
- 7012 Grey
- 8019 Bronze
- 9011 Black/Txt
- 9016 White
- Custom RAL

