

F112 LED Series



Description

The F112 Series luminaire shall consist of an injection molded UV stabilized acorn-shaped diffuser with prismatic optics and a mechanically fastened slip fitter (capital). The diffuser shall consist of A UV stabilized polycarbonate/Acrylic section. The diffuser shall be secured to the gasketed fitter with stainless steel hardware. The fitter shall be made of cast aluminum and shall house LED assembly. The LED shall feature quick disconnect plugs for easy maintenance. The LED shall be factory wired, tested and mounted on a keyed cast aluminum plate. All electrical components shall be UL listed and labeled.

Specification

Housing

Made from a spun aluminum to withstand harsh weather.

Hardware

All exposed hardware is made of durable stainless steel, with industrial strength seals.

Interior Design & Optical

Energy efficient LED driver is mounted on a removable plate, with quick disconnect wiring to allow easy driver maintenance.

L70 at 50,000 hours with CRI 70.

Exterior Design & Finish

The Luminaire is designed to fit post top mounting or pendant mounting with our ornamental arms and poles, and is suitable for wet locations.

Finish is electrostatically applied with thermoset polyester powder-coat.



Dimensions

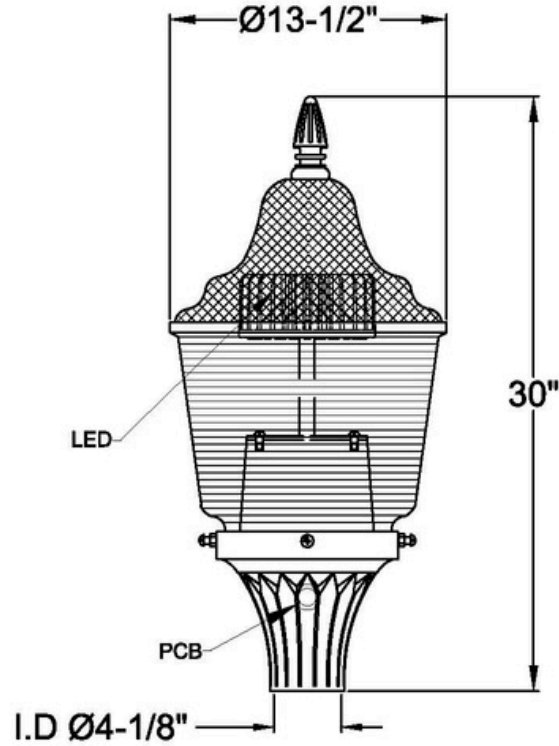

Product Ordering Number

PRODUCT	LUMENS	CCT	VOLTAGES	OPTICS	OPTIONS	FITTER	FINIAL
F112	Max 12600 LMS	3000K 4000K 5000K 6000K	120v-277v 347V 480V	IES TYPE II (2) III (3) IV (4) V (5)	DIM Dimming control PCB Button-type photo- cell HSS House side shield TWL Twist lock system	A, B C, D E, F G, H I, J K, L M, Q R, T U	FA FB FC FD FE FF FG FH FI, FJ

DIFFUSER TYPE

EPG: External Prismatic Glass

Color

- Standard
- RAL
- 6005 Green
- 7012 Grey
- 8019 Bronze
- 9011
- Black/Txt
- 9016 White
- Custom RAL

