

# A376 SERIES

## DESCRIPTION

The arm shall be HCI A376-\_\_\_\_ (specify configuration) arm, consisting of a bent arm welded onto a plate, equipped on the luminaire side with a fixture mounting plate.

## MATERIALS

The arm shall be made of 2-7/8" OD, 3/16" thick aluminum extrusion welded onto cast aluminum wall plate. The scroll shall be made of 1-1/2" x 1/4" aluminum flat bar.

## CONFIGURATION

A variety of configurations is available, most of which are illustrated below. An additional option is noted below in the bottom left-hand corner.

## INSTALLATION

Arms shall be equipped with a 5-1/4" x 5-1/4" aluminum luminaire mounting plate. Arms are not pre-wired and shall be wired by the contractor. Mounting hardware is not included.

## FINISH

All applicable parts shall receive a standard electrostatically applied thermoset polyester powder coat smooth semi gloss finish with a four part corrosion inhibiting process.

## COLORS

The five standard RAL colors are listed below. Simply check off the color applicable to your project. Custom colors are available for an additional charge. Please supply a 2" x 2" paint chip.

- Black** RAL 9011
- Green** RAL 6005
- Bronze** RAL 8019
- Grey** RAL 7012
- White** RAL 9016

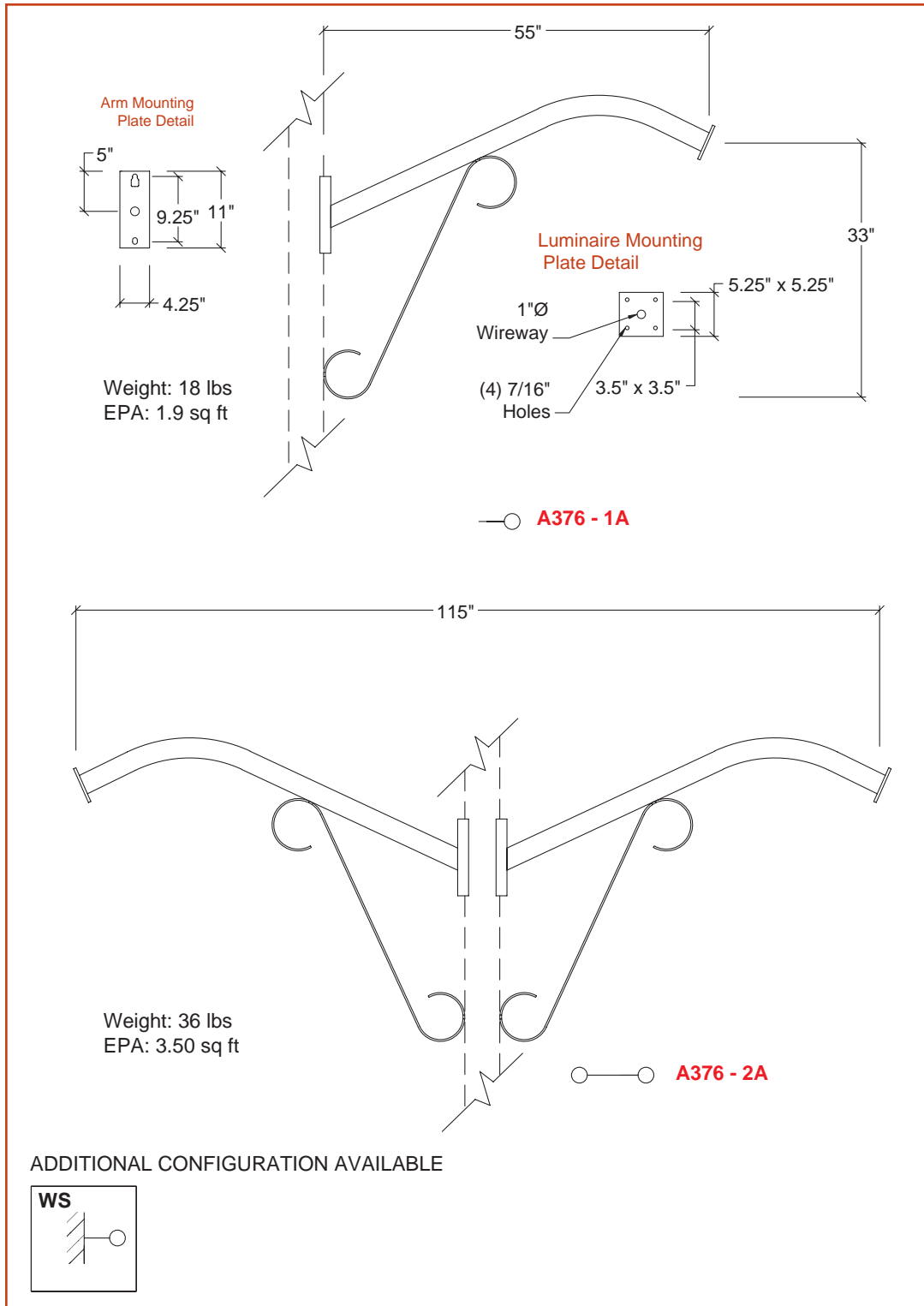

(800) 267-3175 (905) 238-2648  
 1280 Fewster Drive Mississauga  
 Ontario L4W 1A4 Canada  
 Fax (905) 238-9060  
 Email sales@hcilighting.com  
 WEB www.hcilighting.com