

A358 SERIES

DESCRIPTION

The arm shall be HCI A358-____ (specify configuration) arm, consisting of a bent arm with two bent decorative flat bars, welded onto a 4"OD central column, equipped with a pole tenon. Wall bracket shall be welded to an aluminum wall plate.

MATERIALS

The arm shall be made of 2-3/8" OD, 0.154" thick aluminum extrusion and a double bent, decorative aluminum flat bar, 3"W x 1/4" thick, all welded to the extruded non-fluted aluminum column. All hardware shall be tamper resistant, stainless steel.

CONFIGURATION

A variety of configurations is available, some of which are illustrated below. Those not illustrated are noted in the bottom left-hand corner. Non-standard configurations may be feasible, please consult factory for details.

INSTALLATION

Arms shall be equipped with a 12"L x 3-1/2" OD round pole tenon and a 2" ID opening on the fixture side. *Post top* arms are not pre-wired and shall be wired by the contractor. *Wall brackets* shall be pre-wired, with a 12" slack for ease of wiring to source on the wall side and for wiring with wire nuts on the fixture side. Mounting hardware for wall brackets is not included.

FINISH

All applicable parts shall receive a standard electrostatically applied thermoset polyester powder coat smooth semi gloss finish with a four part corrosion inhibiting process.

COLORS

The five standard RAL colors are listed below. Simply check off the color applicable to your project. Custom colors are available for an additional charge. Please supply a 2" x 2" paint chip.

- Black** RAL 9011
- Green** RAL 6005
- Bronze** RAL 8019
- Grey** RAL 7012
- White** RAL 9016
- Custom**

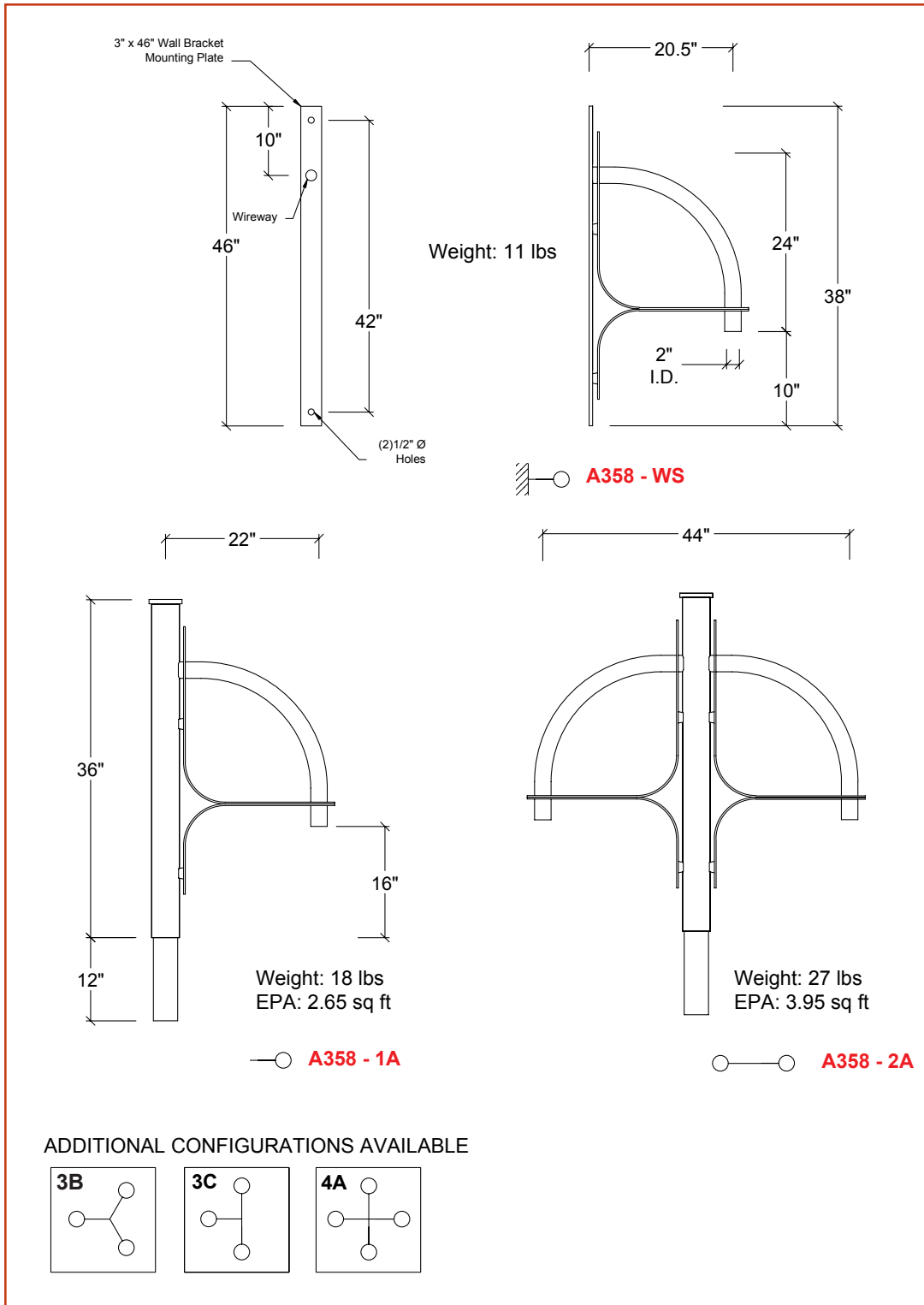

ADDITIONAL CONFIGURATIONS AVAILABLE

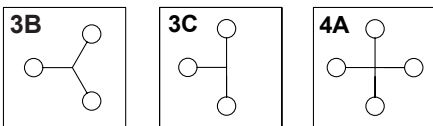

(800) 267-3175 (905) 238-2648
 1280 Fewster Drive Mississauga
 Ontario L4W 1A4 Canada
 Fax (905) 238-9060
 Email sales@hclighting.com
 WEB www.hclighting.com