

A326 SERIES

DESCRIPTION

The arm shall be HCl A326-____ (specify configuration) arm, consisting of a massive casting with an integral tenon, designed to accommodate standard HCl fitters (capitals) for pole mounting.

MATERIALS

The entire arm shall be made of cast aluminum. It shall be designed to accommodate HCl cast aluminum fitters. All hardware shall be tamper resistant, stainless steel.

CONFIGURATION

A variety of configurations is available, as illustrated below. Non-standard configurations may be feasible, please consult factory for details.

INSTALLATION

Post top arms shall be designed to accommodate standard HCl fitters, which will accept a 4"OD x 3"H pole tenon. Arms shall be equipped with 3" (76mm) diameter tenons for fixture mounting. *Post top* arms are not pre-wired and shall be wired by the contractor. *Wall brackets* shall be pre-wired, with a 12" slack for ease of wiring to source on the wall side and for wiring with wire nuts on the fixture side. Mounting hardware for

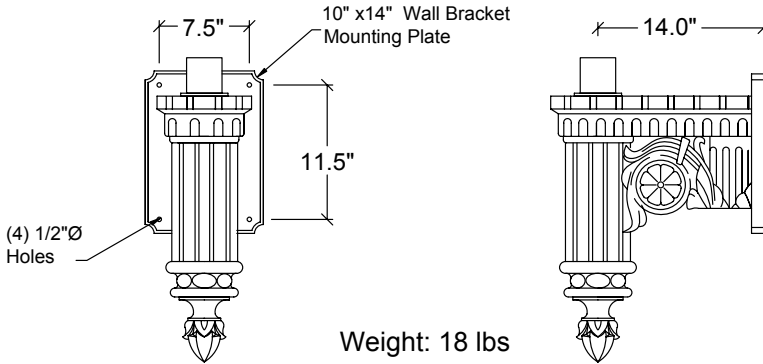

Weight: 18 lbs

 **A326 - WS**

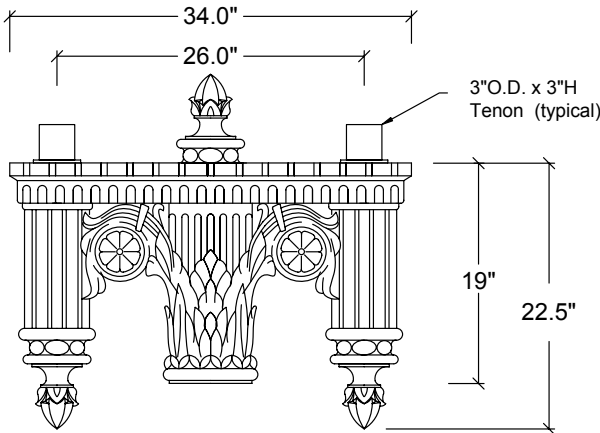

Weight: 74 lbs
EPA: 3.45 sq ft

 **A326 - 2A**

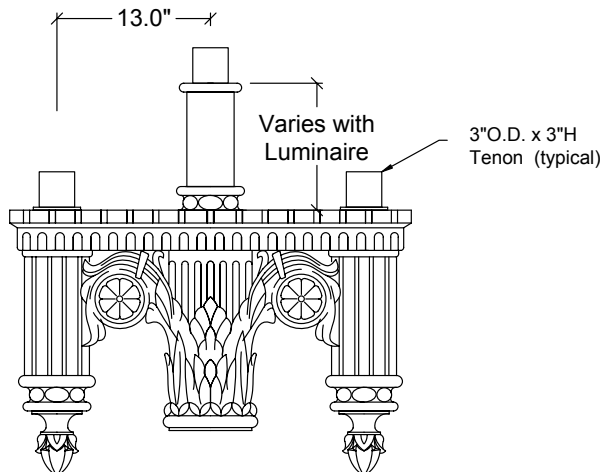

Weight: 74 lbs
EPA: 3.55 sq ft

 **A326 - 3A**

FINISH

All applicable parts shall receive a standard electrostatically applied thermoset polyester powder coat smooth semi gloss finish with a four part corrosion inhibiting process.

COLORS

The five standard RAL colors are listed below. Simply check off the color applicable to your project. Custom colors are available for an additional charge. Please supply a 2" x 2" paint chip.

- | | |
|------------------------|--------------------------|
| Black RAL 9011 | <input type="checkbox"/> |
| Green RAL 6005 | <input type="checkbox"/> |
| Bronze RAL 8019 | <input type="checkbox"/> |
| Grey RAL 7012 | <input type="checkbox"/> |
| White RAL 9016 | <input type="checkbox"/> |
| Custom | <input type="checkbox"/> |



(800) 267-3175 (905) 238-2648
1280 Fewster Drive Mississauga
Ontario L4W 1A4 Canada
Fax (905) 238-9060
Email sales@hclighting.com
WEB www.hclighting.com