

A305 SERIES

DESCRIPTION

Post top arms shall be made of aluminum with an ornamental cast aluminum scroll welded to a round central column. Wall brackets shall be made of aluminum rectangle with a cast aluminum scroll all welded to the cast aluminum wall plate.

MATERIALS

The rectangular 3"x1-1/2"x 1/8" thick arm shall be welded to the ornamental cast scroll. The central 4"OD column shall be made of extruded non-fluted aluminum. All hardware shall be tamper resistant, stainless steel.

CONFIGURATION

A variety of configurations is available, some of which are illustrated below. Those not illustrated are noted in the bottom left-hand corner. Non-standard configurations may be feasible, please consult factory for details.

INSTALLATION

Post top arms shall be equipped with a 12"L x 3-1/2" OD round pole tenon. Arms shall be equipped with 3" (76mm) diameter tenons for fixture mounting. *Post top* arms are not pre-wired and shall be wired by the contractor. *Wall brackets* shall be pre-wired, with a 12" slack for ease of wiring to source on the wall side and for wiring with wire nuts on the fixture side. Mounting hardware for wall brackets is not included.

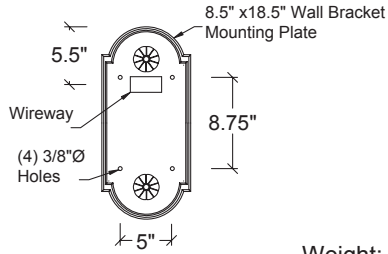

Weight: 8 lbs

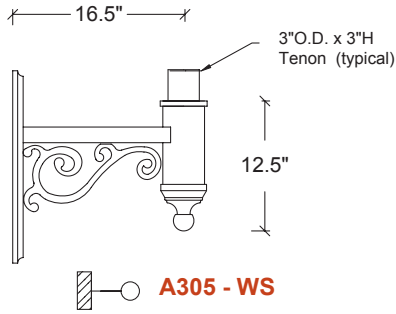

A305 - WS

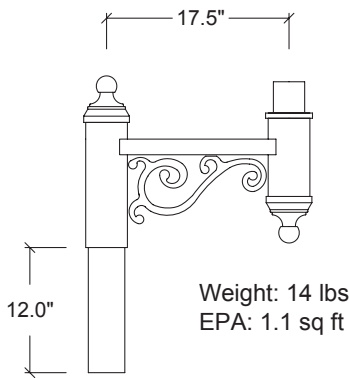

Weight: 14 lbs
EPA: 1.1 sq ft

A305 - 1A

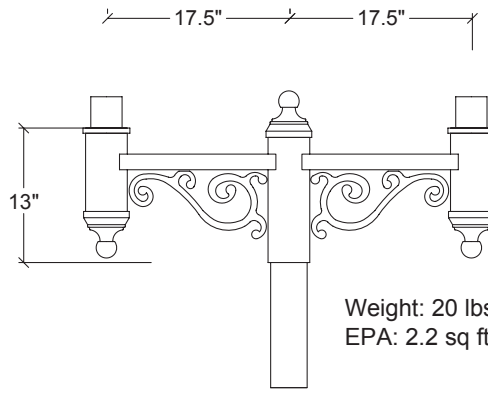

Weight: 20 lbs
EPA: 2.2 sq ft

A305 - 2A

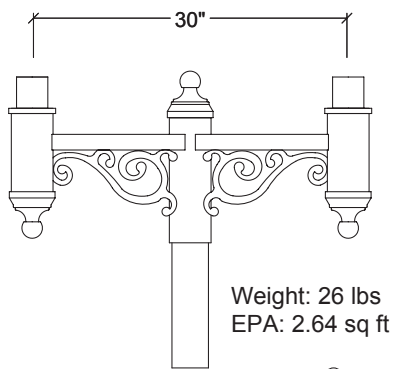

Weight: 26 lbs
EPA: 2.64 sq ft

A305 - 3B

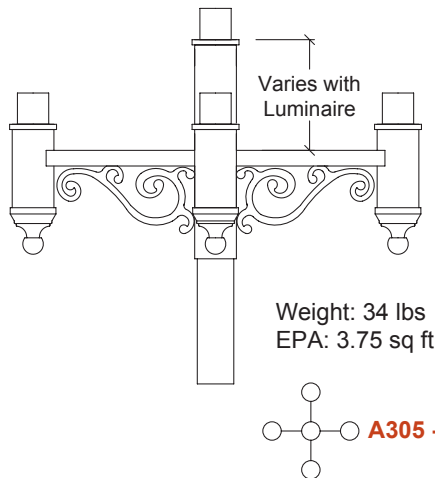

Weight: 34 lbs
EPA: 3.75 sq ft

A305 - 5

ADDITIONAL CONFIGURATIONS AVAILABLE

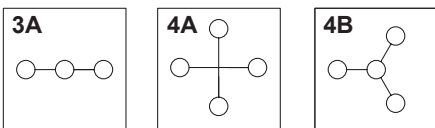

FINISH

All applicable parts shall receive a standard electrostatically applied thermoset polyester powder coat smooth semi gloss finish with a four part corrosion inhibiting process.

COLORS

The five standard RAL colors are listed below. Simply check off the color applicable to your project. Custom colors are available for an additional charge. Please supply a 2" x 2" paint chip.

- Black** RAL 9011
- Green** RAL 6005
- Bronze** RAL 8019
- Grey** RAL 7012
- White** RAL 9016
- Custom**



(800) 267-3175 (905) 238-2648
1280 Fewster Drive Mississauga
Ontario L4W 1A4 Canada
Fax (905) 238-9060
Email sales@hclighting.com
WEB www.hclighting.com