

A300 SERIES

DESCRIPTION

Post top arms shall be made of cast aluminum with a cast aluminum scroll welded to a round central column. Wall brackets shall be made of cast aluminum with a cast aluminum scroll all welded to the cast aluminum wall plate.

MATERIALS

The arm and scroll shall be cast as one piece. The central column shall be made of extruded non-fluted aluminum. All hardware shall be tamper resistant, stainless steel.

CONFIGURATION

A variety of configurations is available, some of which are illustrated below. Those not illustrated are noted in the bottom left-hand corner. Non-standard configurations may be feasible, please consult factory for details.

INSTALLATION

Post top arms shall slip-fit 10" over a 3-1/2" (89mm) round pole tenon. Arms shall be equipped with 3" (76mm) diameter tenons for fixture mounting. *Post top* arms are not pre-wired and shall be wired by the contractor. *Wall brackets* shall be pre-wired, with a 12" slack for ease of wiring to source on the wall side and for wiring with wire nuts on the fixture side. Mounting hardware for wall brackets is not included.

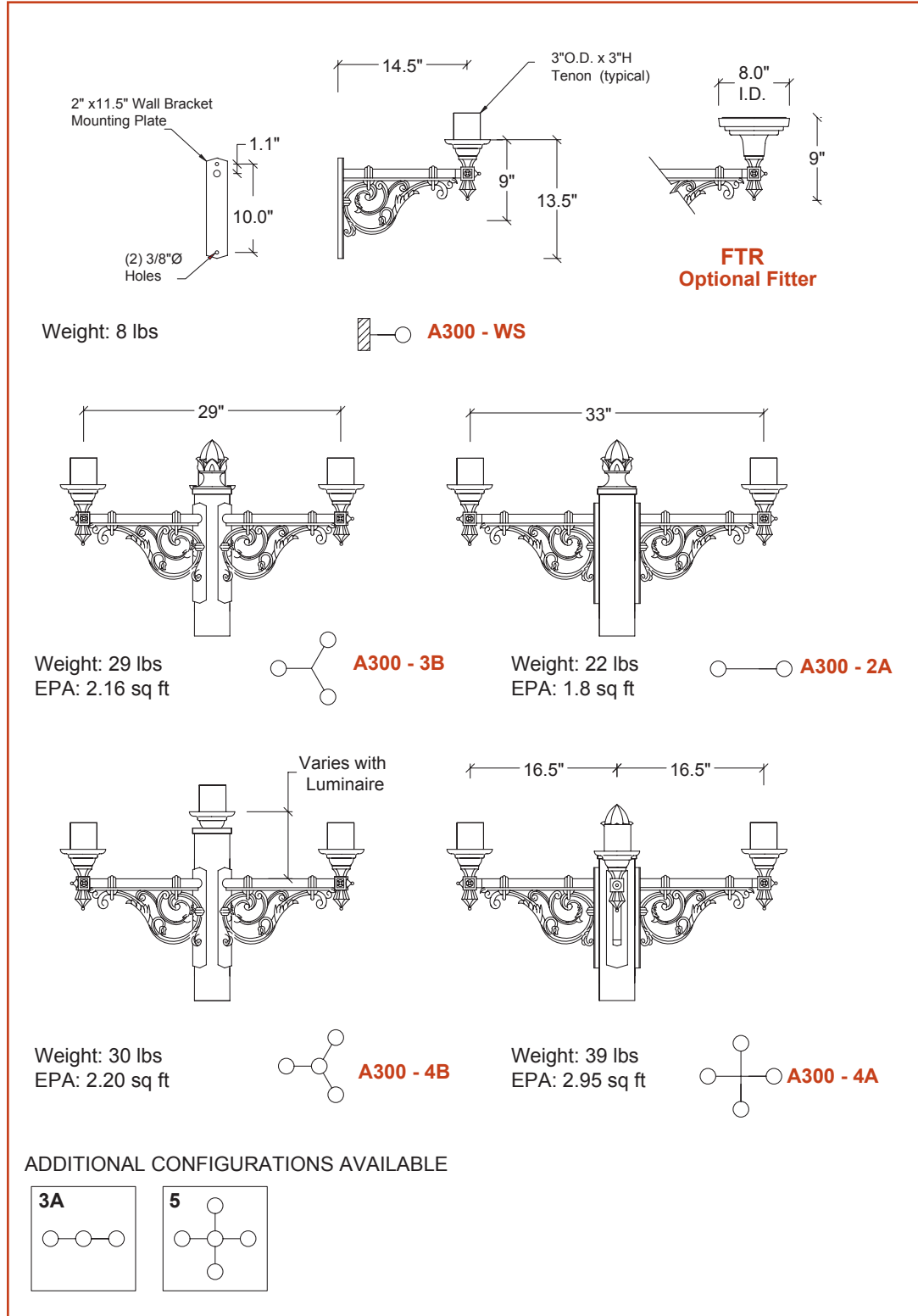

2" x 11.5" Wall Bracket Mounting Plate
 (2) 3/8"Ø Holes
 1.1"
 10.0"

14.5"
 3"O.D. x 3"H Tenon (typical)
 9"
 13.5"
 8.0" I.D.
 9"
FTR Optional Fitter

Weight: 8 lbs
A300 - WS

29"
 Weight: 29 lbs
 EPA: 2.16 sq ft
A300 - 3B

33"
 Weight: 22 lbs
 EPA: 1.8 sq ft
A300 - 2A

Varies with Luminaire
 16.5" 16.5"
 Weight: 30 lbs
 EPA: 2.20 sq ft
A300 - 4B

Weight: 39 lbs
 EPA: 2.95 sq ft
A300 - 4A

ADDITIONAL CONFIGURATIONS AVAILABLE

3A
5

FINISH

All applicable parts shall receive a standard electrostatically applied thermoset polyester powder coat smooth semi gloss finish with a four part corrosion inhibiting process.

COLORS

The five standard RAL colors are listed below. Simply check off the color applicable to your project. Custom colors are available for an additional charge. Please supply a 2" x 2" paint chip.

- Black** RAL 9011
- Green** RAL 6005
- Bronze** RAL 8019
- Grey** RAL 7012
- White** RAL 9016
- Custom**



(800) 267-3175 (905) 238-2648
 1280 Fewster Drive Mississauga
 Ontario L4W 1A4 Canada
 Fax (905) 238-9060
 Email sales@hcilighting.com
 WEB www.hcilighting.com